

ETA-Danmark A/S
Kollegievej 6
DK-2920 Charlottenlund
Tel. +45 72 24 59 00
Fax +45 72 24 59 04
Internet www.etadanmark.dk



Authorised and notified according to Article 10 of the Council Directive 89/106/EEC of 21 December 1988 on the approximation of laws, regulations and administrative provisions of Member States relating to construction products

MEMBER OF EOTA

European Technical Approval ETA-00/0003

English translation, the original version is in Danish

| | |
|---|---|
| Trade name: | NOOD trap mounted in gully type PURUS ODEN, FLEX, VÅGE, BRAGE, LOKE, S/50 L MA, LOD, SIGYN, SIGEX, BALDER or BALDEX |
| Holder of approval: | Purus ab Södergatan 7 S-27521 Sjöbo Tel. +46 416 257 00 Fax +46 416 257 20 |
| Generic type and use of construction product: | Trap with partially mechanical closure, mounted in a non-trapped gully |
| Valid from: | 2005-07-04 |
| to: | 2010-07-04 |
| Extended from: | 2010-11-23 |
| to: | 2015-11-23 |
| Manufacturing plant: | Purus ab Södergatan 7 S-27521 Sjöbo |

This European Technical Approval contains:

15 pages including 6 Annexes which form an integral part of the document



European Organisation for Technical Approvals

Europæisk Organisation for Tekniske Godkendelser

I LEGAL BASIS AND GENERAL CONDITIONS

- 1 This European Technical Approval is issued by ETA-Danmark A/S in accordance with:
 - Council Directive 89/106/EEC of 21 December 1988 on the approximation of laws, regulations and administrative provisions of Member States relating to construction products¹⁾, as amended by Council Directive 93/68/EEC of 22 July 1993²⁾.
 - Bekendtgørelse 559 af 27-06-1994 (afløser bekendtgørelse 480 af 25-06-1991) om ikrafttræden af EF direktiv af 21. december 1988 om indbyrdes tilnærmelse af medlemsstaternes love og administrative bestemmelser om byggevarer.
 - Common Procedural Rules for Requesting, Preparing and the Granting of European Technical Approvals set out in the Annex to Commission Decision 94/23/EC³⁾.
- 2 ETA-Danmark A/S is authorized to check whether the provisions of this European Technical Approval are met. Checking may take place in the manufacturing plant. Nevertheless, the responsibility for the conformity of the products to the European Technical Approval and for their fitness for the intended use remains with the holder of the European Technical Approval.
- 3 This European Technical Approval is not to be transferred to manufacturers or agents of manufacturers other than those indicated on page 1, or manufacturing plants other than those indicated on page 1 of this European Technical Approval.
- 4 This European Technical Approval may be withdrawn by ETA-Danmark A/S, in particular pursuant to Article 5(1) of Council Directive 89/106/EEC.
- 5 Reproduction of this European Technical Approval including transmission by electronic means, shall be in full. However, partial reproduction can be made with the written consent of ETA-Danmark A/S. In this case partial reproduction has to be designated as such. Texts and drawings of advertising brochures shall not contradict or misuse the European Technical Approval.
- 6 This European Technical Approval is issued by ETA-Danmark A/S in Danish. This version corresponds fully to the version circulated within EOTA. Translations into other languages have to be designated as such.

1) Official Journal of the European Communities N° L40, 11 Feb 1989, p 12.
2) Official Journal of the European Communities N° L220, 30 Aug 1993, p 1.
3) Official Journal of the European Communities N° L 17, 20 Jan 1994, p 34.

II SPECIFIC CONDITIONS OF THE EUROPEAN TECHNICAL APPROVAL

1 Definition of product and intended use

1.1 Definition of the construction product

The kit consists of a trap with partially mechanical closure, mounted in a range of non-trapped gullies.

The **trap, PURUS NOOD**, (see Figure 3 in Annex 2) is made of polypropylene and designed as a bottle trap with a dip tube, but contrary to an ordinary bottle trap the bowl is loosely fixed to the dip tube by means of a spring which is designed in such a way that the trap in unused condition is closed (see Figure 1 in Annex 1). The spring is made of stainless steel 2331-06.

When water runs into the gully the imposed water weight will move the bowl downwards and open the trap (see Figure 2 in Annex 1).

When no water is running into the gully, the bowl will by means of the spring return to the top position, close the trap and supply a mechanical seal in addition to the water seal.

The **gully** is one of the following ranges:

PURUS ODEN
PURUS FLEX
PURUS VÅGE
PURUS BRAGE
PURUS LOKE
PURUS S/50 L MA
PURUS LOD
PURUS SIGYN
PURUS SIGEX
PURUS BALDER
PURUS BALDEX

Made of plastic, cast iron or stainless steel and with vertical or horizontal outlets, and in some cases with side inlets (see overview in Table 1 in Annex 3 and Figures 4 - 14 in Annex 4).

1.2 Intended use

The trapped gully is for use in buildings for domestic waste water and designed for installation in concrete floors with a watertight covering of PVC or ceramic tiles.

The **grating** is either **SL/150 S** (made of polypropylene) or **PURUS STRONG** (made of polycarbonate) (see Figure 15 in Annex 5).

A **clamping ring, KL**, (see Figure 16 in Annex 6) is used for installation in floors with watertight covering of PVC.

An **extension connection, FH**, (see Figure 17 in Annex 6) is used for non-buried use, e.g. in floors with concrete on a layer of wooden beams.

The trapped gully ensures that:

- No gases or foul air will enter the room if the water in the water seal evaporates
- No insects or similar can enter the room via the drainage system.

The tests and assessment have been based on the assumption that the working life of PURUS NOOD mounted in PURUS ODEN, FLEX, VÅGE, BRAGE, LOKE, S/50 L MA, LOD, SIGYN, SIGEX, BALDER or BALDEX with SL/150 S or PURUS STRONG and with relevant use of KL and FH for the above described intended use is at least **25 years**. This can not be understood as a guarantee given by Purus ab or ETA-Danmark A/S.

2 Characteristics of product and methods of verification

| Product characteristic | Assessment of characteristic |
|--|--|
| 2.1 Mechanical resistance and stability | Not relevant. |
| 2.2 Safety in case of fire | Not relevant |
| 2.3 Hygiene, health and the environment | |
| 2.3.1 Water tightness | The kit is watertight according to EN 1253-2, clause 10.2 and EN 1253-1, clauses 8.9.2 and 8.9.6 |
| 2.3.2 Tightness for sheet floor covering and/or membrane | When fitted with KL clamping ring, the kit is watertight according to EN 1253-2, clause 10.3 and EN 1253-1, clauses 8.9.3 and 8.9.4 |
| 2.3.3 Odour tightness | The kit is odour tight according to EN 1253-2, clause 10.1 and EN 1253-1, clause 8.9.1 |
| 2.3.4 Blockage prevention | The kit has sufficient blockage prevention according to Annex 4 of the CUAP for draft request 07.04/04 dated 1999-08-27 |
| 2.3.5 Access for cleaning | The kit has sufficient provision for cleaning and rodding the outlet systems leading to and from the kit, according to EN 1253-2, clause 7.1 and EN 1253-1, clause 8.6.1 |
| 2.3.6 Water through the grating | The flow rates through the grating as determined according to EN 1253-2, clause 11.1 fulfil the requirements in EN 1253-1, clause 8.11.1 |
| 2.3.7 Water through the grating and side inlets | The flow rates through the grating and side inlets as determined according to EN 1253-2, clause 11.2 fulfil the requirements in EN 1253-1 clause 8.11.2 |
| 2.3.8 Water through the side inlet | The flow rates through the side inlets as determined according to EN 1253-2, clause 11.2 fulfil the requirements in EN 1253-1, clause 8.11.3 |
| 2.4 Safety in use | |
| 2.4.1 Loading strength | The kit has the following loading strength classes according to EN 1253-2, clause 4: H 1,5 for grating PURUS SL/150 S K 3 for grating PURUS STRONG |
| 2.4.2 Mechanical strength for extension connection | FH extension connection has sufficient mechanical strength according to EN 1253-2, clause 10.4.1 and EN 1253-1, clause 8.10.1 |

| Product characteristic | Assessment of characteristic |
|---|--|
| 2.4.3 Mechanical strength for clamping ring | KL clamping ring has sufficient mechanical strength according to EN 1253-2, clause 10.4.2 and EN 1253-1, clause 8.10.2 |
| 2.4.4 Temperature cycling | The kit has sufficient resistance to temperature cycling according to EN 1253-2, clause 9.1 and EN 1253-1, clauses 8.8.1 and 8.8.2 |
| 2.4.5 Apertures in gratings | The kit fulfils the requirements to permissible apertures dimensions according to EN 1253-2, clause 6 and EN 1253-1, clause 8.5 |
| 2.5 Protection against noise | Not relevant |
| 2.6 Energy economy | Not relevant |
| 2.7 Aspects of durability | |
| 2.7.1 Mechanical durability | The spring is made of stainless steel 2331-06 and is in accordance with DIN 2095: 1973, Zylindrische Schraubenfedern aus runden Drähten, Gutevorschriften für kaltgeformte Druckfedern. The spring has a sufficient mechanical durability. |

EN 1253-1 refers to EN 1253-1 Gullies for buildings - Part 1: Requirements

EN 1253-2 refers to EN 1253-2 Gullies for buildings - Part 2: Test methods

3 Evaluation of Conformity and CE marking

3.1 System of Attestation of Conformity

The system of attestation of conformity applied to this product shall be that laid down in the CPD, Annex III, 2(ii), third possibility (referred to as System 4) and is detailed as follows:

Tasks of the manufacturer

- (1) Initial type testing of the product
- (2) Factory production control.

3.2 Responsibilities

3.2.1 Tasks of the manufacturer

3.2.1.1

The manufacturer shall exercise permanent internal control of production. All the elements, requirements and provisions adopted by the manufacturer shall be documented in a systematic manner in the form of written policies and procedures, including records of results performed. This production control system shall insure that the product is in conformity with this European technical approval.

The manufacturer may only use raw materials stated in the technical documentation of this European technical approval.

The factory production control shall be in accordance with EN 1253-3 [Gullies for buildings - Part 3: Quality control].

3.2.1.2 Initial type testing of the product

For initial type testing the results of the tests performed as part of the assessment for this European Technical Approval shall be used unless there are changes in the production line or plant. In such cases the necessary type testing has to be agreed between ETA-Danmark A/S and the manufacturer.

3.3 CE marking

The CE marking shall be affixed to the packaging and accompanying commercial documents.

The CE marking shall be accompanied by the following information:

- Name of product (commercial trade name as referred in the ETA)
- Name or identifying trade mark of the manufacturer and the manufacturing plant
- Last two digits of the year in which the marking was affixed
- Number of the ETA: ETA-00/0003

Factory production control.

4 Assumptions under which the fitness of the product for the intended use was favourably assessed

4.1 Manufacturing

All materials shall be manufactured by Purus ab or its subcontractors.

The European technical approval is issued for the product on the basis of agreed data/information, deposited with ETA-Danmark A/S, which identifies the product that has been assessed and judged. Changes to the product or production process, which could result in this deposited data/information being incorrect, should be notified to ETA-Danmark A/S before the changes are introduced. ETA-Danmark A/S will decide whether or not such changes affect the ETA and consequently the validity of the CE marking on the basis of the ETA and if so whether further assessment or

alterations to the ETA, shall be necessary.

4.2 Installation

Application and installation details are given in the Manufacturer's Installation Guide dated 1997-07-01 which forms part of this ETA and which shall always accompany the delivered system. Non-used side inlets and connections to side inlets shall be made watertight.

5 Indications to the manufacturer

5.1 Maintenance and repair

The kit shall be removed and cleaned regularly.



Thomas Bruun
Manager, ETA-Danmark

Annex 1

Figures 1 and 2 Schematic diagrams showing the principle of the spring in the trap

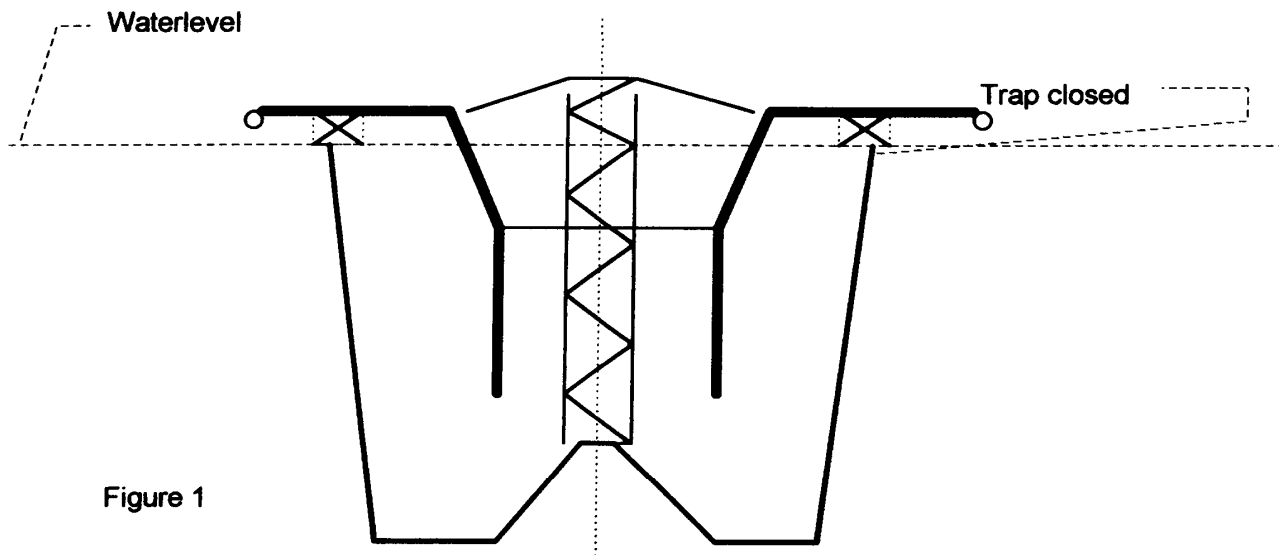

Figure 1

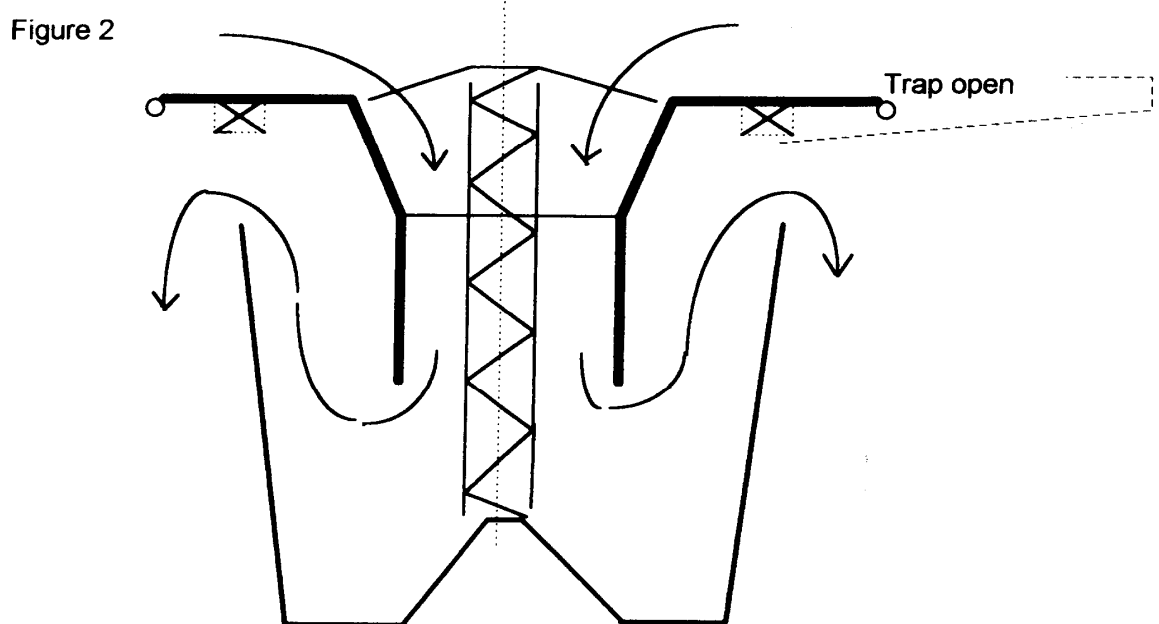
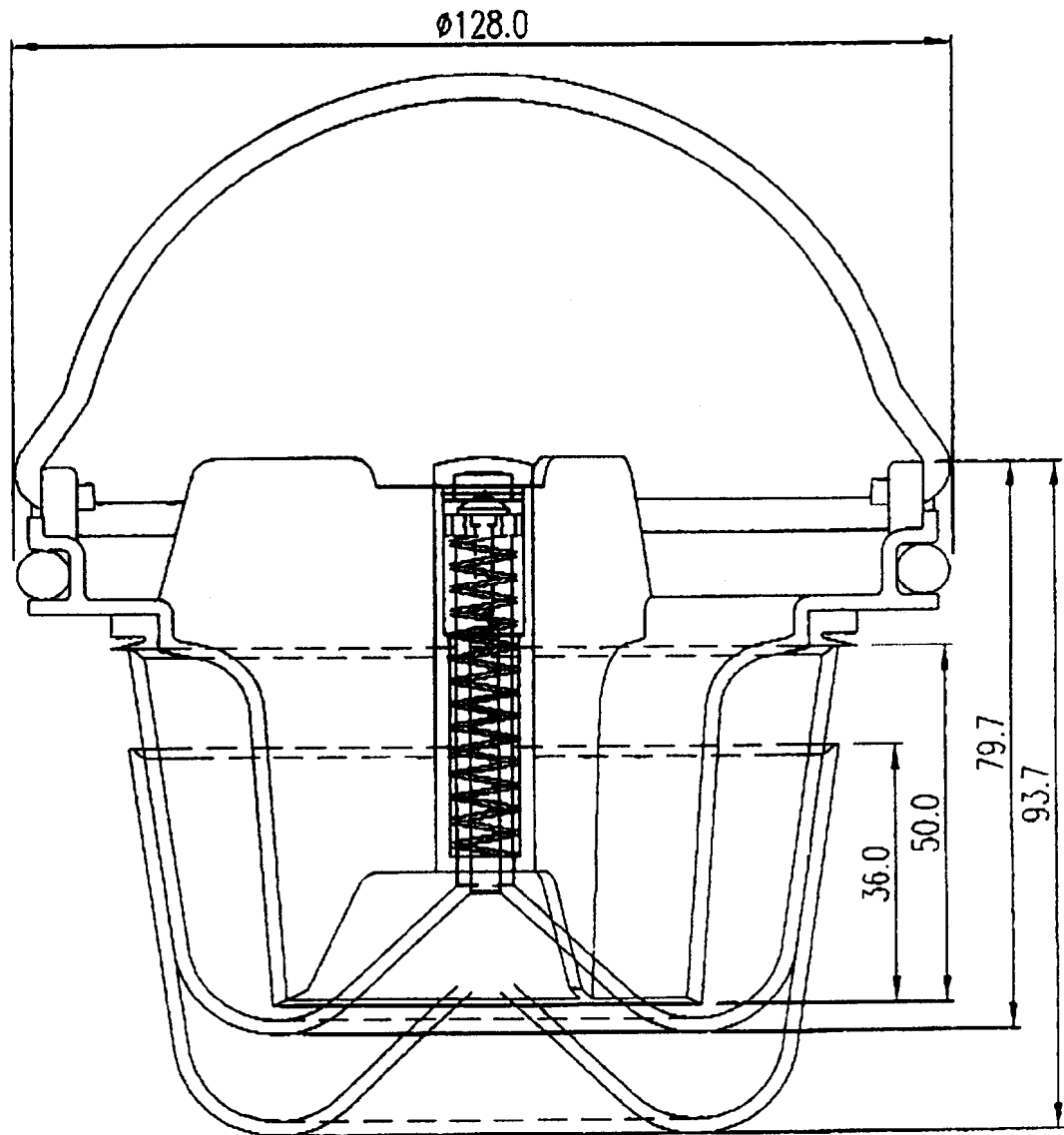

Figure 2

Annex 2

Figure 3 Drawing of PURUS NOOD



Annex 3

Table 1 Overview of range of gullies and the maximum flows

| PURUS gully type | Material of gully | Outlet | Nominal size of outlet (mm) | Number of side inlets |
|------------------|-------------------|------------|-----------------------------|-----------------------|
| ODEN | PP or PEH | Horizontal | 75 | - |
| FLEX | PP | Horizontal | 75 | - |
| VÅGE | PP | Horizontal | 75 | 3 |
| BRAGE | ABS | Vertical | 75 | - |
| LOKE | PP | Vertical | 75 | 3 |
| S/50 L MA | Cast iron | Horizontal | 75 | - |
| LOD | Cast iron | Vertical | 75 | - |
| SIGYN | Stainless steel | Horizontal | 75 | - |
| SIGEX | Stainless steel | Horizontal | 75 | 4 |
| BALDER | Stainless steel | Vertical | 75 | - |
| BALDEX | Stainless steel | Vertical | 75 | 4 |

Annex 4

Figure 4 Drawing of PURUS ODEN

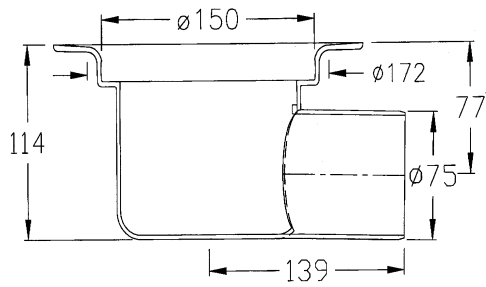

Figure 5 Drawing of PURUS FLEX

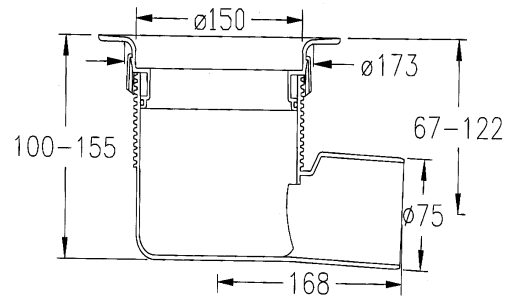

Figure 6 Drawing of PURUS VÅGE

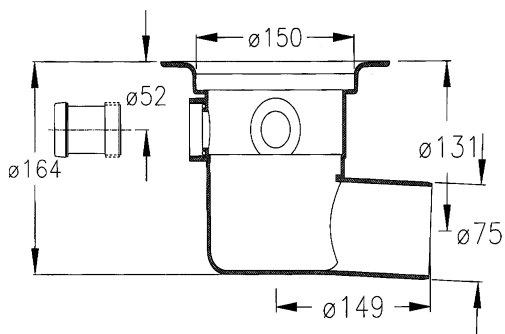
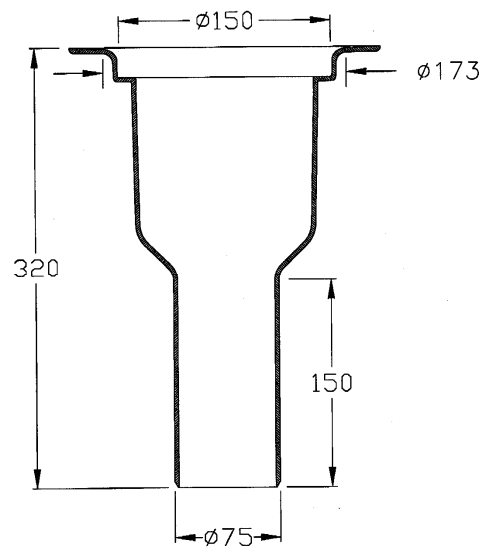

Figure 7 Drawing of PURUS BRAGE



Annex 4 continued

Figure 8 Drawing of PURUS LOKE

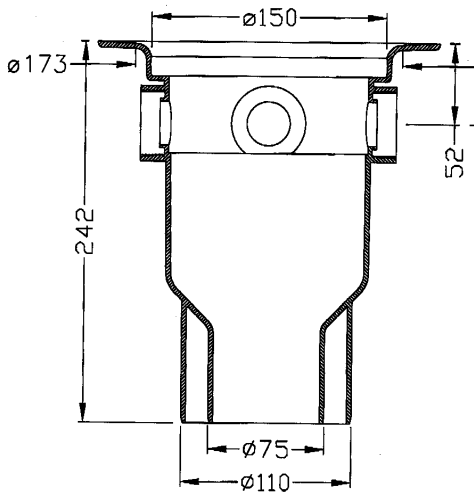

Figure 9 Drawing of PURUS S/50 L MA

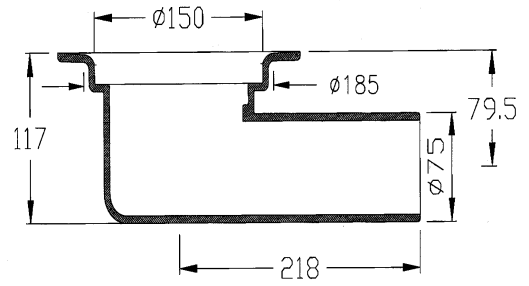

Figure 10 Drawing of PURUS LOD

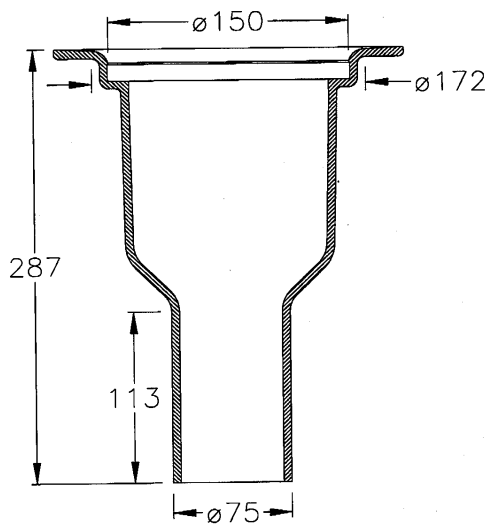
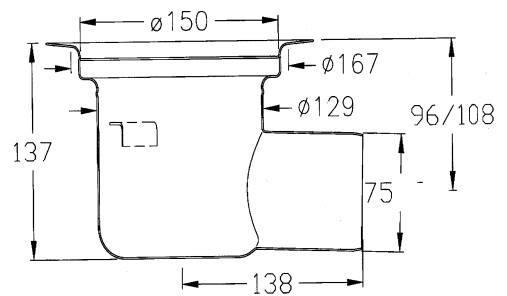

Figure 11 Drawing of PURUS SIGYN



Annex 4 continued

Figure 12 Drawing of PURUS SIGEX

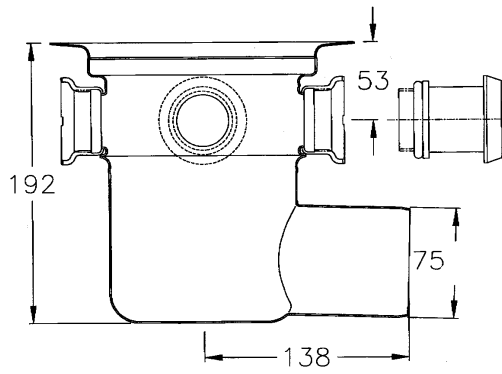

Figure 13 Drawing of PURUS BALDER

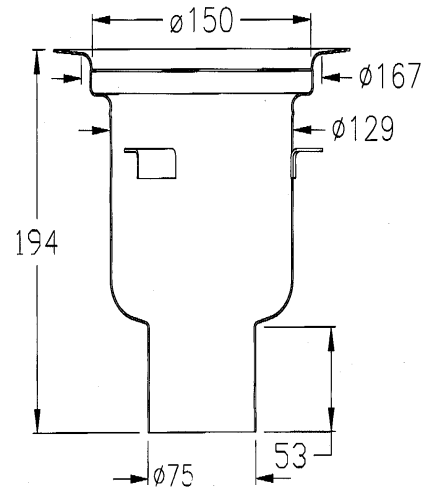
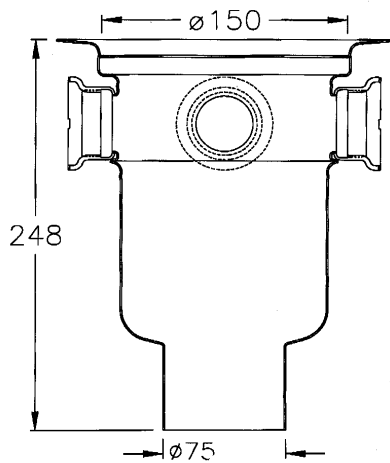

Figure 14 Drawing of PURUS BALDEX



Annex 5

Figure 15 Drawing of grating PURUS SL/150 S (polypropylene)
or PURUS STRONG (polycarbonate)



Annex 6

Figure 16 Drawing of clamping ring KL

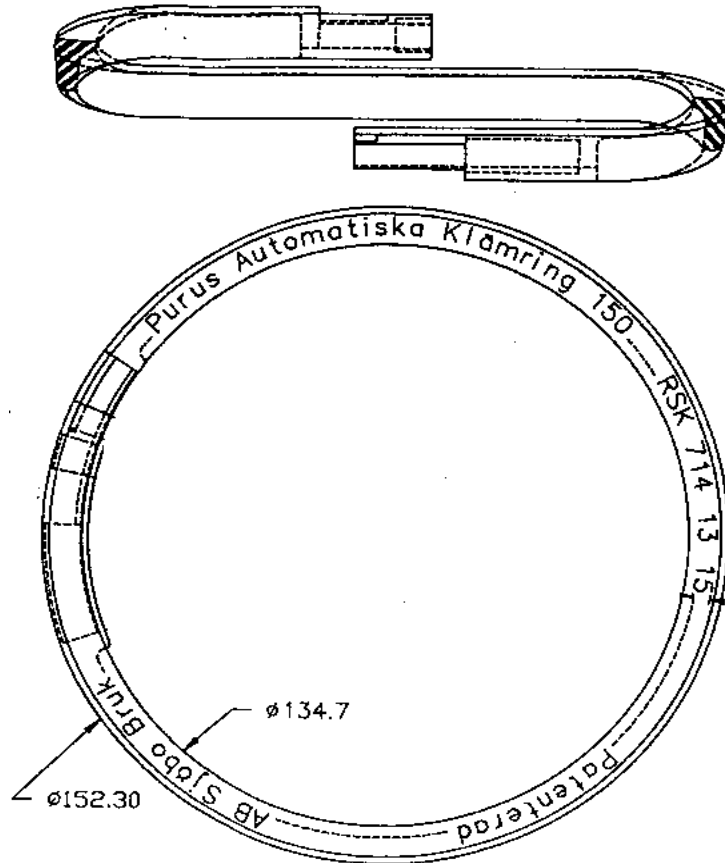

Figure 17 Drawing of extension connection FH

